

## Standard Equipment/Optional Equipment

### Standard Equipment

Long tiller with low mounting point  
 Fibre-glass reinforced tiller and tiller head (Grivory®)  
 Exxtral® motor and battery cover  
 Creep speed control (L12, L12i)  
 Proportional speed control (L12, L12i)  
 End-of-stroke resistance  
 Storage compartments  
 OptiLift® proportional lift system (L10, L12, L12i)  
 Hand protection at rear of mast (polycarbonate or steel mesh)  
 Multi-function display with hourmeter including scheduled maintenance, fault code and battery discharge indicator  
 Key switch or LFM Go (PIN-code access)  
 AC motor  
 Linde LAC controller

CAN-bus architecture  
 Electromagnetic brake  
 Automatic parking brake  
 Cushion rubber drive wheel  
 Single polyurethane load wheels  
 Fork length: 1150 mm  
 Width over forks: 560 mm  
 Initial lift (L12i)  
 Built-in or built-out fork carriage  
 Protection to -10°C  
 Vertical 2 PzS-B battery change (L10B, L10, L12)  
 Vertical 3 PzS-B battery change (L12i)  
 Horn  
 Clipboard

### Optional Equipment

Drive wheels: polyurethane, wet grip, non marking cushion, treaded cushion  
 Load wheels: Tandem polyurethane, tandem polyurethane greasable  
 Alternative fork lengths and widths  
 Load backrest  
 Creep speed control (L10)  
 Proportional speed control (L10)

Linde Connected Solutions:  
 ac:access control (PIN or RFID Dual), an:usage analysis and dt:crash detection  
 Cold store protection to -35°C  
 Automatic battery watering system  
 Built-in charger  
 High frequency charger

Other options available on request

### Li-ION technology

Fast Full Charge  
 Opportunity Charging  
 Fast Intermediate Charging  
 Maintenance Free  
 Long Lifetime  
 Good performance in Cold Store

### Li-ION batteries

- specific lithium-ion battery compartment: 1,8kWh-3,6kWh (24V/82-164Ah)  
**Optimized 24V-Li-ION charger** - v90: 1,8kWh (82 Ah) - v160: 3,6kWh (164 Ah)



## Electric Pallet Stackers Capacity 1000 - 1200 kg L10B, L10, L12, L12i

Series 1172

Linde Material Handling



### Safety

The hand guards of the off-centred tiller head effectively shield hands and keep the operator safely within the truck's contours with excellent visibility through the mast. The long tiller mounted low down on the chassis ensures ample safety clearance between operator and truck.

### Performance

The combination of a new AC motor and Linde LAC digital controller makes these pallet stackers highly efficient. Operating parameters can be adjusted to match any application. The OptiLift mast control assures accurate, fully proportional lifting as well as smooth and quiet operation.

### Comfort

All controls on the ergonomic tiller head can be easily operated by either hand. A Creep speed button offers utmost manoeuvrability in confined areas. Proportional speed automatically alters traction speed in relation to the truck/operator distance. Finished in tactile materials, these stackers deliver accurate load handling for better productivity.

## Features

### Steering system

- Proportional speed control varies truck speed automatically in relation to the tiller angle for safe, comfortable and productive operation
- A Creep speed button ensures high manoeuvrability in confined areas when operating at low speeds with tiller in upright position
- End-of-stroke resistance on the tiller avoids accidental, abrupt braking
- Soft tiller fold-back slows down the tiller when returning into upright position, avoiding the tiller snapping on the motor cover

### AC motor & Booster effect

- Powerful, smooth-running 1.2 kW AC motor
- Traction speed adjustable up to 6 km/h, laden or unladen
- Booster effect provides higher torque when additional power is needed
- No roll-back on hill starts



### Braking system

- Highly efficient electro-magnetic brake applied by moving tiller to fully up or down position
- Automatic braking on releasing traction butterfly or by reversing direction
- Truck slows before coming to a stop, remaining under total control at all times



### Tiller & Tiller head

- Off-set, ergonomic Grivory® tiller head ensures safety and visibility
- Long tiller with low mounting point provides safety clearance between operator and chassis
- Wrap-around hand protection
- Comfortable controls, operable with either hand and gloves



### Chassis

- Compact, rounded shape avoids snagging
- Highly resistant, robust steel construction
- Low chassis skirt protects operator's feet

### Lifting system

- OptiLift mast control provides accurate, fully proportional lifting as well as smooth and quiet operation
- Soft landing of the forks protects load when lowering
- Wide range of mast options available
- Choice of standard or built-out carriage depending on application
- Initial lift on L12i ensures easy crossing of ramps and dock levellers

### Working station & Display

- Wide, deep storage compartment for shrink wrap, pens, markers etc.
- Durable and long lasting Exxtral® motor and battery cover
- Multi-function display as standard with hourmeter including scheduled maintenance, fault code and battery discharge indicator



### Maintenance and CAN-bus architecture

- Zero maintenance, moisture and dust-proof 1.2 kW AC motor
- CAN-bus architecture enables fast, easy access to all truck data
- Individually adjustable parameters via diagnostic plug
- Rapid and convenient access to main components via front service panel

Linde Material Handling GmbH, Postfach 10 01 36, 63701 Aschaffenburg, Germany  
 Phone +49.60 21.99-0, Fax +49.60 21.99-15 70, www.linde-mh.com, info@linde-mh.com

Linde Material Handling



# Technical Data according to VDI 2198

		LINDE					
		LINDE	LINDE	LINDE	LINDE		
Characteristics	1.1	Manufacturer	LINDE	LINDE	LINDE	LINDE	
	1.2	Manufacturer's type designation	<b>L121</b>	<b>L10B / [L10B ION]<sup>1)</sup></b>	<b>L10 / [L10 ION]<sup>1)</sup></b>	<b>L12 / [L12 ION]<sup>1)</sup></b>	
	1.2a	Series	1172	1172	1172	1172	
	1.3	Power unit	Battery	Battery	Battery	Battery	
	1.4	Operation	Pedestrian	Pedestrian	Pedestrian	Pedestrian	
	1.5	Load capacity/Load	Q (t)	1.2	1.0	1.0	1.2
	1.6	Load centre distance	c (mm)	600	600	600	600
	1.8	Axle centre to fork face	x (mm)	780 / 709 <sup>2)3)</sup>	715 <sup>4)</sup>	695 <sup>3)</sup>	695 <sup>3)</sup>
	1.9	Wheelbase	y (mm)	1362 / 1291 <sup>2)</sup>	1157 [1177] <sup>1)</sup>	1157 [1177] <sup>1)</sup>	1157 [1177] <sup>1)</sup>
Weights	2.1	Service weight	(kg)	909	708	788	788
	2.2	Axle load with load, front/rear	(kg)	744 / 1365	617 / 1091 [616 / 1092]	654 / 1134 [653 / 1135]	671 / 1317 [669 / 1319]
	2.3	Axle load without load, front/rear	(kg)	643 / 266 <sup>3)</sup>	518 / 190	572 / 216	572 / 216
Wheels/Tyres	3.1	Tyres rubber, SE, pneumatic, polyurethane		V+P/P <sup>6)</sup>	V+P/P <sup>6)</sup>	V+P/P <sup>6)</sup>	V+P/P <sup>6)</sup>
	3.2	Tyre size, front		Ø 230 x 75	Ø 230 x 75	Ø 230 x 75	Ø 230 x 75
	3.3	Tyre size, rear		2x Ø 85 x 85	2x Ø 85 x 100	2x Ø 85 x 100	2x Ø 85 x 100
	3.4	Auxiliary wheels (dimensions)		Ø 140 x 54	Ø 140 x 54	Ø 140 x 54	Ø 140 x 54
	3.5	Wheels, number front/rear (x = driven)		1x + 1 / 2	1x + 1 / 2	1x + 1 / 2	1x + 1 / 2
	3.6	Track width, front	b10 (mm)	518	518	518	518
	3.7	Track width, rear	b11 (mm)	380	380	380	380
Dimensions	4.2	Height of mast, lowered	h1 (mm)	1996	2390	1940	1940
	4.3	Free lift	h2 (mm)	150	1912	150	150
	4.4	Lift	h3 (mm)	2424	1912	2924	2924
	4.5	Height of mast, extended	h4 (mm)	4868	2390	3402	3402
	4.6	Initial lift	h5 (mm)	130	-	-	-
	4.9	Height of tiller arm in operating position, min/max	h14 (mm)	650 / 1190	650 / 1190	650 / 1190	650 / 1190
	4.15	Height, lowered	h13 (mm)	86	86	86	86
	4.19	Overall length	l1 (mm)	1907 <sup>7)</sup>	1768 [1788] <sup>1)7)</sup>	1788 [1808] <sup>1)7)</sup>	1788 [1808] <sup>1)7)</sup>
	4.20	Length to fork face	l2 (mm)	757	618 [638] <sup>1)</sup>	638 [658] <sup>1)</sup>	638 [658] <sup>1)</sup>
	4.21	Overall width	b1/b2 (mm)	800	800	800	800
	4.22	Fork dimensions DIN ISO 2331	s/e/l (mm)	65 x 180 x 1150 <sup>8)</sup>	65 x 180 x 1150 <sup>8)</sup>	65 x 180 x 1150 <sup>8)</sup>	65 x 180 x 1150 <sup>8)</sup>
	4.24	Width of fork carriage	b3 (mm)	534	534	534	534
	4.25	Fork spread	b5 (mm)	560	560	560	560
	4.32	Ground clearance, centre of wheelbase	m2 (mm)	20 / 150 <sup>2)</sup>	30	30	30
	4.34.1	Aisle width for pallets 1000 x 1200 crossways	Ast (mm)	2480 (2061) / 2437 (2061) <sup>2)9)10)11)</sup>	2324 (1945) [2344 (1965)] <sup>9)10)11)</sup>	2333 (1965) [2353 (1985)] <sup>9)10)11)</sup>	2305 (1937) [2325 (1957)] <sup>9)10)11)</sup>
4.34.2	Aisle width with pallet 800 x 1200 along forks	Ast (mm)	2421 (2261) / 2403 (2261) <sup>2)9)10)11)</sup>	2289 (2145) [2309 (2165)] <sup>9)10)11)</sup>	2304 (2165) [2324 (2185)] <sup>9)10)11)</sup>	2276 (2137) [2296 (2157)] <sup>9)10)11)</sup>	
4.35	Turning radius	Wa (mm)	1641 / 1570 <sup>2)11)</sup>	1460 [1480] <sup>1)</sup>	1460 [1480] <sup>1)</sup>	1432 [1452] <sup>1)11)</sup>	
Performance	5.1	Travel speed, with/without load	(km/h)	6 / 6	6 / 6	6 / 6	6 / 6
	5.2	Lifting speed, with/without load	(m/s)	0.11 / 0.225	0.09 / 0.2	0.1 / 0.2	0.11 / 0.225
	5.3	Lowering speed, with/without load	(m/s)	0.4 / 0.3	0.23 / 0.23	0.35 / 0.35	0.4 / 0.3
	5.8	Maximum climbing ability, with/without load	(%)	10.0 / 15.0	5.0 / 10.0	5.0 / 10.0	5.0 / 10.0
	5.9	Acceleration time, with/without load	(s)	8.3 / 7.0	8.0 / 7.0	8.0 / 7.0	8.3 / 7.0
	5.10	Service brake		Electro-magnetic	Electro-magnetic	Electro-magnetic	Electro-magnetic
Drive	6.1	Drive motor rating S2 60 min	(kW)	1.2	1.2	1.2	1.2
	6.2	Lift motor rating at S3 15%	(kW)	2.5	0.9	1	2.5
	6.3	Battery according to DIN 43531/35/36 A,B,C,no		no	no	no	no
	6.4	Battery voltage/rated capacity (5h)	(V)/(Ah)	24 / 225 <sup>12)</sup>	24 / 180 [24 / 82] <sup>1)</sup>	24 / 180 [24 / 82] <sup>1)</sup>	24 / 180 [24 / 82] <sup>1)</sup>
	6.5	Battery weight (± 5%)	(kg)	200	195 [51] <sup>1)</sup>	195 [51] <sup>1)</sup>	195 [51] <sup>1)</sup>
	6.6	Power consumption according to VDI cycle	(kWh/h)	1	0.7	0.8	1
8.1	Type of drive unit		LAC	LAC	LAC	LAC	
10.7	Sound pressure level LpAZ (at the driver's seat)	(dB(A))	65	65	65	65	

- 1) Figures in [ ] with Li-ION battery see line 6.4
- 2) Without/with initial lift
- 3) With Simplex masts + 20 mm, with Triplex masts - 57 mm. Forks carriages with fork thickness s = 60 mm, preferred while using gitter box, are also available: the x dimension decreases of -44 mm for Simplex masts and -35 mm for Standard and Duplex masts.
- 4) With Standard mast - 20 mm. Forks carriages with fork thickness s = 60 mm, preferred while using gitter box, are also available: the x dimension decreases of -44 mm for Simplex masts and -35 mm for Standard mast.
- 5) Forks lowered
- 6) Solid rubber + polyurethane / polyurethane
- 7) with fork length l = 1000 mm l1 decreases of -150 mm.
- 8) Optionally 65 x 180 x 1000
- 9) Calculated with VDI 2198 (VDI 3597)
- 10) Including a 200 mm (min.) operating aisle clearance.
- 11) With creep speed = tiller in vertical position
- 12) Trough number 68

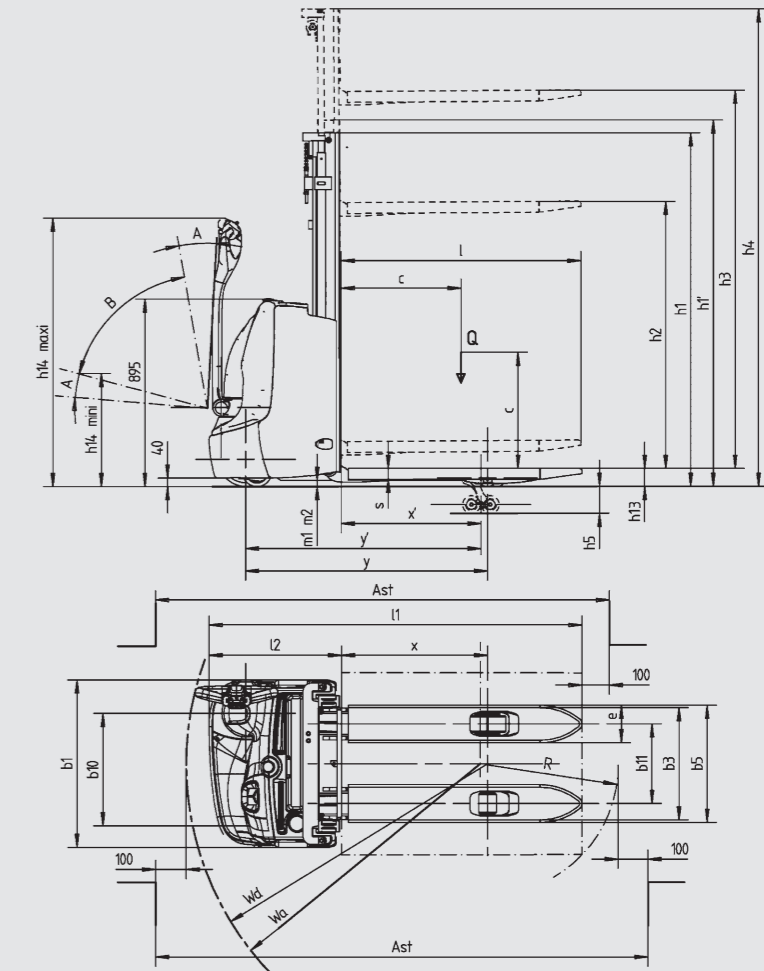

$$Ast = Wa + \sqrt{(l6 - x)^2 + \left(\frac{b12}{2}\right)^2} + a$$

$$Ast = Wa + R + a$$

Safety clearance a = 200 mm

Masts (L10/L12) (in mm)	1462 E	1912 E	2024 S	2424 S	2924 S	3324 S	3824 S	4224 S	
Lift	<b>h3</b>	1462	1912	2024	2424	2924	3324	3824	4224
Lift + fork height	<b>h3+h13*</b>	1547	1997	2109	2509	3009	3409	3909	4309
Height lowered	<b>h1*</b>	1940	2390	1490	1690	1940	2140	2390	2590
Height raised	<b>h4</b>	1943	2393	2502	2902	3402	3802	4302	4702
Free lift	<b>h2</b>	1462	1912	150	150	150	150	150	150

Masts (L10/L12) (in mm)	2024 D	2424 D	2924 D	3324 D	3824 D	4224 D	3636 T	4386 T
Lift	<b>h3</b>	2024	2424	2924	3324	3824	4224	4386
Lift + fork height	<b>h3+h13*</b>	2109	2509	3009	3409	3909	3409	4471
Height lowered	<b>h1*</b>	1490	1690	1940	2140	2390	2590	1940
Height raised	<b>h4</b>	2502	2902	3402	3802	4302	4702	4868
Free lift	<b>h2</b>	1012	1212	1462	1662	1912	2112	1462

\* Initial lift h5 = 130 mm  
E=Simplex mast, S=Standard mast, D=Duplex mast, T=Triplex mast