



## Electric Platform Tractor Capacity 2000 kg W 20

SERIES 127-02

### Safety

The heavy duty chassis and cab module provide assured protection for the operator while three independent braking systems deliver responsive stopping power for all situations including automatic speed control descending gradients. A low centre of gravity ensures outstanding stability.

### Performance

With the dual capability carrying 2 tonne on the platform and towing nominal loads of 4.5 tonne, the W 20 offers flexible high performance which is optimised by the Linde digital AC control system that provides precise, energy saving control of acceleration and speed for high productivity. The curved front screen and profiled chassis ensures excellent manoeuvrability.

### Comfort

A low step facilitates access to spacious operator's cabin where the automotive layout of the pedals, direction lever, steering wheel and controls, together with a fully adjustable suspension seat provides a comfortable and fatigue-free working environment. Cab suspension dampers and a spring damped suspension system front and rear ensures superb levels of driving comfort.

### Reliability

Designed for intensive heavy duty applications the rugged, robot-welded chassis is constructed from heavy section steel plate for optimum torsional stiffness and rounded corners for high resistance to impacts. All key components are protected within the chassis while electronic components are housed in sealed aluminium enclosures for assured reliability and long life.

### Productivity

Two powerful, high torque 2.5 kW AC drive motors provide impressive pulling and carrying power for a variety of applications. The energy saving Linde AC digital controller combined with excellent manoeuvrability and an intuitive interface between the operator and tractor, translates that power into versatile, seamless performance and high productivity.

Linde Material Handling

*Linde*

# Technical data (according to VDI 2198)

		LINDE			
		W 20 (2200)	W 20 (2600)		
Characteristics	1.1	Manufacturer	LINDE		
	1.2	Model designation	W 20 (2200)	W 20 (2600)	
	1.3	Power unit: battery, diesel, petrol, LP gas, mains power	Battery	Battery	
	1.4	Operation: manual, pedestrian, stand-on, seated, order picker	Seated	Seated	
	1.5	Carried load capacity	Q (t)	2	2
	1.7	Rated drawbar pull, with/without carried load	F (N)	500/900 <sup>1)</sup> - 800/1200 <sup>1)</sup>	500/900 <sup>1)</sup> - 800/1200 <sup>1)</sup>
	1.9	Wheelbase	y (mm)	1900	1900
Weight	2.1	Service weight	kg	3100	3200
	2.2	Axle load with load, front/rear	kg	2300/2800	2100/3100
	2.3	Axle load without load, front/rear	kg	1800/1300	1800/1400
Wheels and tyres	3.1	Tyres, front/rear (SE = CS superelastic, P = pneumatic)		P/P <sup>2)</sup>	P/P <sup>2)</sup>
	3.2	Tyre size, front		6.00 R9	6.00 R9
	3.3	Tyre size, rear		7.00 R12	7.00 R12
	3.5	Wheels, number front/rear (x = driven)		2/2x	2/2x
	3.6	Track width, front	b10 (mm)	1080	1080
	3.7	Track width, rear	b11 (mm)	1020	1020
	Dimensions	4.7	Height of overhead guard (cabin)	h6 (mm)	1820
4.8		Height of seat/stand-on platform	h7 (mm)	745	745
4.12		Towing coupling height, minimum/maximum	h10 (mm)	240, 295, 350, 405	240, 295, 350, 405
4.13		Platform height, without load	h11 (mm)	840	840
4.16		Loading platform, length	l3 (mm)	2200	2600
4.17		Rear overhang	l5 (mm)	730	1130
4.18		Loading platform, width	b9 (mm)	1300	1300
4.19		Overall length	l1 (mm)	3530	3930
4.21		Overall width	b1 (mm)	1300	1300
4.32		Ground clearance, centre of wheelbase	m2 (mm)	150	150
4.35		Turning radius	Wa (mm)	3280	3280
4.36		Minimum pivoting point distance	b13 (mm)	1095	1095
Performance	5.1	Travel speed, with/without carried load	km/h	15/20 - 20/25	15/20 - 20/25
	5.5	Drawbar pull at 60 minute rating, with/without carried load	N	500/900 - 800/1200	500/900 - 800/1200
	5.6	Maximum drawbar pull, with/without carried load (on level ground)		5600/6000 <sup>3)</sup> - 9600/10000 <sup>3)</sup>	5600/6000 <sup>3)</sup> - 9600/10000 <sup>3)</sup>
	5.7	Climbing ability with/without load, 30 minute rating	%	See graph	See graph
	5.8	Maximum climbing ability, with/without load, 5 minute rating	%	See graph	See graph
	5.10	Service brake		Hydraulic/electric	Hydraulic/electric
Drive	6.1	Drive motor, 60 minute rating	kW	2 x 2.5 <sup>4)</sup> - 2 x 10 <sup>4)</sup>	2 x 2.5 <sup>4)</sup> - 2 x 10 <sup>4)</sup>
	6.3	Battery according to DIN 43531/35/36 A, B, C, no		DIN 43536A	DIN 43536A
	6.4	Battery voltage/rated capacity (5h)	V/Ah	80/320 <sup>4)</sup>	80/320 <sup>4)</sup>
	6.5	Battery weight	(± 0,5%) kg	858	858
	6.6	Power consumption according to VDI cycle	kWh/h	<sup>3)</sup>	<sup>3)</sup>
	Other	8.1	Type of drive control		AC-microprocessor
8.4		Noise level at operator's ear	dB (A)	<sup>3)</sup>	<sup>3)</sup>
8.5		Tow coupling, design/type, DIN/no		<sup>3)</sup>	<sup>3)</sup>

<sup>1)</sup> Based on level, dry surface with rolling resistance of 200 N/t.

Refer to graph opposite for specific operating conditions and when the application involves inclines or ramps.

<sup>2)</sup> Contoured solid (superelastic) tyres are available.

<sup>3)</sup> Refer to manufacturer for figures.

<sup>4)</sup> High torque 2x10 kW motor is available in conjunction with 320 Ah battery only.

# Equipment

## Standard equipment

### General

Four wheel configuration
Pneumatic tyres
Platform length 2,200 mm
Tractor without cab
Left or right hand drive steering position
Adjustable steering column
Comprehensive integrated display
Single pedal accelerator and direction lever
Full suspension PVC driver's seat
Non-suspension PVC passenger seat
Hydrostatic power steering
Front and rear screen wipers/washers (with optional cab version)
Two exterior mirrors
Interior mirror
Interior light
Remote inching control
Automatic single position, rear towing coupling
Trailer lighting socket
Dual circuit hydraulic disc brakes on all four wheels
Integrated in drive axle with no differential required
Superb traction with anti-slip control
Reduced power to inner wheel during cornering
High-torque flexibility and performance
Standard colour scheme – vermilion and charcoal grey

### Electronics

80 V circuit
2 x 2.5 kW maintenance free AC drive motors
Advanced Linde AC digital controller
Precise control of speed and acceleration
Highly efficient energy saving system
Programmable performance parameters

### Batteries and chargers

80 V, 210 to 320 Ah to IEC
Easy battery change
A range of chargers is available to suit application and main supply requirements

### Safety

Three independent braking systems
Hydraulic disc brakes (front) external disc brakes (rear)
Regenerative electric braking as accelerator pedal is released
Superb regenerative braking control on gradients
Electric push-button parking brake
Keyswitch
Emergency circuit isolator
Fail-to-safe circuitry
Traction isolated by seatswitch and/or parking brake
Electrical overload protection
Comprehensive warning lights
Electric horn
Full road lighting
Excellent all-round visibility
Driver's cab with safety glass

## Optional equipment

Platform length 2,600 mm
Cab with front and rear screens, wipers and washers, and two exterior mirrors:
- without sides or
- with flexible roll up sides or
- hinged doors
Electric or diesel heater and demister
High torque (2 x 10 kW) drive motor - only with 320 Ah battery
Rear lights mounted high at rear of cab
Flashing or rotating beacon on cab
Reverse warning beeper
Contoured solid (superelastic) tyres

Towing couplings:
- Automatic single position, front and/or rear
- Automatic single position, remote, rear
- Multi-position, front and/or rear
240 mm rear coupling extension
Remote inching control
Aluminium lift-out side panels
Hinged aluminium side panels with or without flexible cover and framework
Fabric covered seats
Heated seats
Full suspension passenger seat
Alternative colour schemes

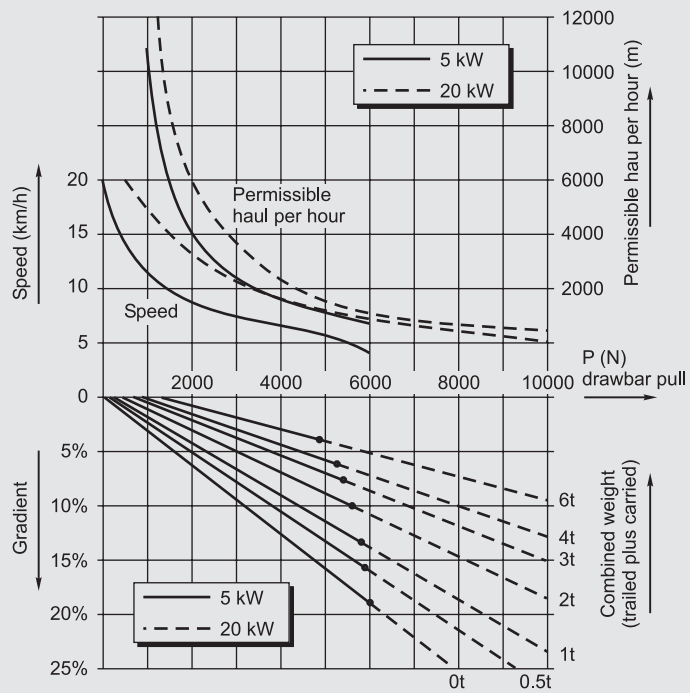
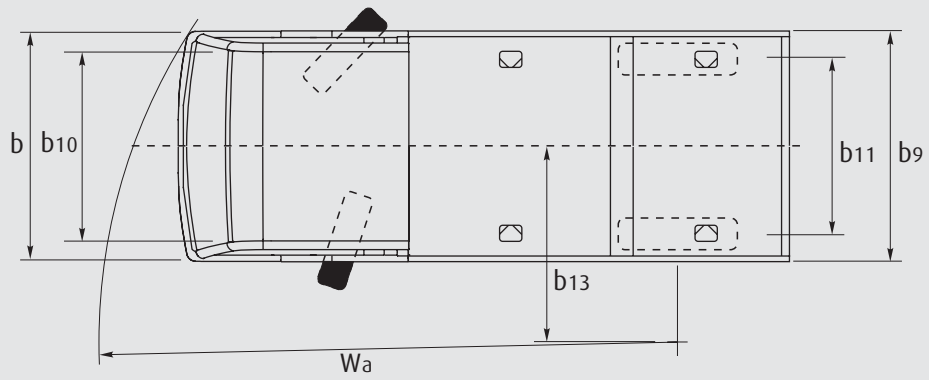
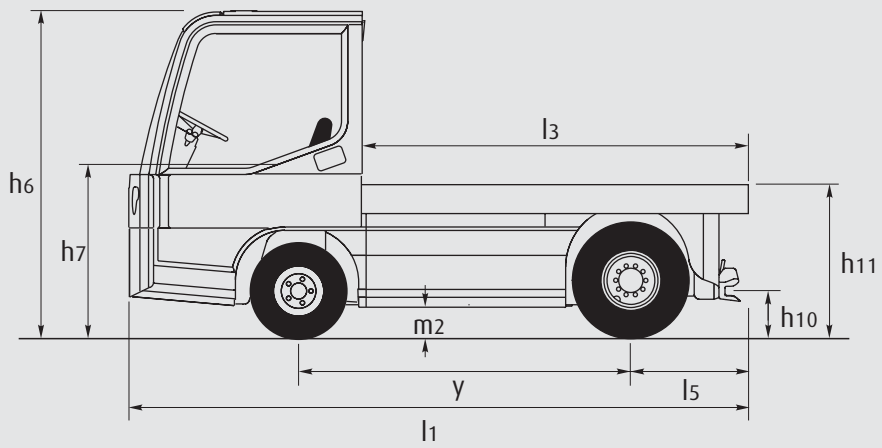



# Features

## Chassis

- Long and short platform versions
- Robot welded heavy gauge steel plate
- Maximum torsional resistance and rigidity
- High impact protection for operator and components
- Low profile chassis for all-round visibility



## Ergonomics

- Ergonomic automotive pedal and control layout
- Spacious leg and headroom
- Storage space for documents, pens and beverage holder
- Excellent all-round visibility

## Operator's compartment

- Low step access to spacious cabin
- Hinged cabin doors
- Fully adjustable comfort-class operator's seat
- Cabin isolated from chassis by hydraulic dampers
- Ergonomic automotive pedal and control layout
- Multi-function instrument display



## Steering

- Hydrostatic power steering
- Effortless manoeuvrability
- Adjustable steering column
- Large lock-to-lock angle



## Braking

- Three independent braking systems
- Electric push-button parking brake
- Hydraulic disc brakes (front) external disc brakes (rear)
- Regenerative electric braking as accelerator pedal is released
- Superb regenerative braking control on gradients



## Platform

- Generously proportioned platform
- 2,200 mm or 2600 mm platform length
- Easily adapted to suit specific applications
- Optional side panels and rigid covers

## Drive units

- Two 2,5 kW maintenance-free AC drive motors
- Integrated in drive axle with no differential required
- Superb traction with anti-slip control
- Reduced power to inner wheel during cornering
- High-torque flexibility and performance

## Serviceability

- Easy access for maintenance and battery
- CAN bus diagnostic facility for reduced service intervals
- Multi-function instrument display assists scheduled maintenance planning
- Maintenance-free AC drive technology

Subject to modification in the interests of engineering progress. Illustrations and technical details non-binding for actual construction. All measurements subject to customary tolerances.

