



## Electric Pallet Stackers Capacity 1400 and 1600 kg L14, L16/L14i, L16i

SERIES 372

### Safety

The Linde Electric Pallet Stacker is equipped with three independent braking systems. A special booster circuit prevents the truck rolling back when starting on a gradient. Automatic speed reduction when cornering ensures stability in operation. The rounded contours of the chassis contribute to safe load handling whilst the long, low mounted tiller ensures that the operator is kept well away from the chassis.

### Performance

A chassis width of only 800 mm allows the truck to work easily in narrow aisles. Advanced chassis design and mast construction results in market leading residual capacity. Linde OptiLift® control provides true proportional lifting and lowering. A rated capacity of 1,600 kg and a powerful 3 kW lift motor ensure superior performance and optimum productivity.

### Comfort

Electric power steering and the ergonomic Linde tiller make the truck very easy to manoeuvre. All controls can be operated with either hand without having to let go of the tiller. Due to the long tiller, the operator stands well back from the mast ensuring excellent visibility of the load right up to maximum lift height.

### Reliability

These rugged trucks incorporate tried and tested technology and components to ensure consistent reliability. They have already proved their ability to deliver faster, safer load handling over an extended working life in the toughest industrial environments. For heavy duty applications, twin castor wheels are available as an option.

### Service

Linde Pallet Stackers are designed to reduce maintenance costs and deliver the highest levels of productivity over many years. Fast, easy access to all components, electronics sealed in aluminium housings isolating them from road shocks, dust and humidity all play a part in guaranteeing high availability.

Linde Material Handling

*Linde*

# Technical data

Characteristics	1.1	Manufacturer		Linde	Linde	Linde
	1.2	Model designation		L 14	L 16	L 14i
	1.3	Power unit: Battery, diesel, gasoline, LP gas, AC		Battery	Battery	Battery
	1.4	Operation: manual, pedestrian, rider seat, rider stand, order picker		Pedestrian	Pedestrian	Pedestrian
	1.5	Load capacity	Q (kg)	1400	1600	1400 (2000)
	1.6	Load center	c (mm)	600	600	600
	1.8	Load distance	x (mm)	727	727	649/727
	1.9	Wheelbase	y (mm)	1304	1304	1226/1304
Weights	2.1	Service weight	kg	1050 <sup>2)</sup>	1050 <sup>2)</sup>	1050 <sup>2)</sup>
	2.2	Axle load with load, operator/load side	kg	850/1600	860/1790	850/1600
	2.3	Axle load without load, operator/load side	kg	735/315	735/315	735/315
Wheels and tyres	3.1	Tyres: operator/load side: Rubber (R), polyurethane (PU)		R+PU/PU	R+PU/PU	R+PU/PU
	3.2	Tyre size, operator side	mm	ø 230 x 90	230 x 90	230 x 90
	3.3	Tyre size, load side	mm	ø 85 x 85	85 x 85	85 x 85
	3.4	Auxiliary wheels, size	mm	ø 150 x 50	150 x 50	150 x 50
	3.5	Wheels, number operator/load side (x=driven)		1 x + 1/2	1 x + 1/2	1 x + 1/4
	3.6	Track width, operator side	mm	520	520	520
	3.7	Track width, load side	mm	380	380	380
Measurements	4.2	Mast height, lowered	h1 (mm)	1990	1990	1990
	4.3	Free lift	h2 (mm)	150	150	150
	4.4	Lift	h3 (mm)	2924	2844	2924
	4.5	Mast height, extended	h4 (mm)	3460	3380	3460
	4.6	Initial lift	h5 (mm)	-	-	125
	4.9	Tiller height, travel position, min./max.	h14 (mm)	750/1126	750/1126	750/1126
	4.15	Fork height, lowered	h13 (mm)	86	86	86
	4.19	Overall length	l1 (mm)	1950	1950	1950
	4.20	Length to fork face	l2 (mm)	800	800	800
	4.21	Overall width	b1/b2 (mm)	800	800	800
	4.22	Fork dimensions	s/e/l (mm)	71/180/1150	71/180/1150	71/180/1150
	4.24	Fork carriage width	b3 (mm)	780	780	780
	4.25	Fork spread	b5 (mm)	560/680	560/680	560/680
	4.32	Ground clearance, centre of wheelbase	m2 (mm)	30	30	145/20
	4.33	Aisle width, 1000 x 1200 mm pallet crosswise	Ast (mm)	-	-	-
4.34	Aisle width, 800 x 1200 mm pallet lengthwise	Ast (mm)	2346	2346	2346	
4.35	Turning radius	Wa (mm)	1527	1527	1527	
Performance	5.1	Travel speed, with/without load	km/h	5.6/6.0	5.5/6.0	5.6/6.0
	5.2	Lift speed, with/without load	m/s	0.16/0.25 (0.40) <sup>1)</sup>	0.14/0.22 (0.37) <sup>1)</sup>	0.16/0.25 (0.40) <sup>1)</sup>
	5.3	Lower speed, with/without load	m/s	0.45/0.45	0.40/0.35	0.45/0.45
	5.7	Climbing ability, with/without load	m/s	-	-	-
	5.8	Max. climbing ability, with/without load	%	9.0-10	8.0-10	9.0-10
	5.10	Service brake		Electromechanical	Electromechanical	Electromechanical
Drive	6.1	Drive motor output (60 min. rating)	kW	1.2	1.2	1.2
	6.2	Lift motor output (15% rating)	kW	3.0	3.0	3.0/0.8
	6.3	Battery (IEC)		254-2	254-2	254-2
	6.4	Battery voltage	V/Ah	24/220	24/220	24/220
	6.5	Battery weight	kg	200	200	200
	6.6	Energy consumption, VDI Cycle	kWh/h	-	-	-
Other	8.1	Drive controller		LDC with microprocessor	LDC with microprocessor	LDC with microprocessor
	8.4	Sound level at driver's ear	dB (A)	<65	<65	<65

Figures for standard version may vary when optional equipment is fitted.

1) Figures in parentheses for optional ultra fast lifting.

2) Including battery weight stated in Line 6.4.

Linde
L 16i
Battery
Pedestrian
1600 (2000)
600
649/727
1226/1304
1050 <sup>3)</sup>
850/1790
735/315
R+PU/PU
230 x 90
85 x 85
150 x 50
1 x + 1/4
520
380
1990
150
2844
3380
125
750/1126
86
1950
800
800
71/180/1150
780
560/680
145/20
-
2346
1527
5.5/6.0
0.14/0.22 (0.37) <sup>3)</sup>
0.40/0.35
-
8.0-10
Electromechanical
1.2
3.0/0.8
254-2
24/220
200
-
LDC with microprocessor
<65

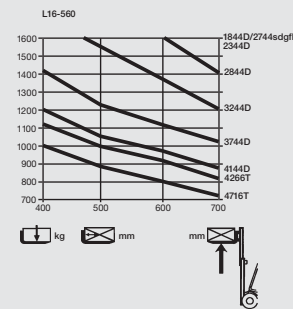
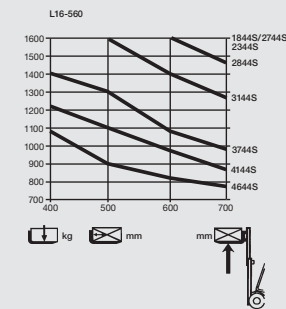
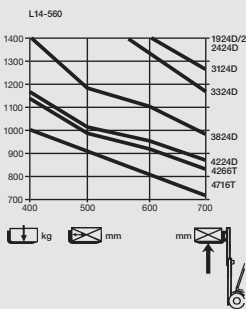
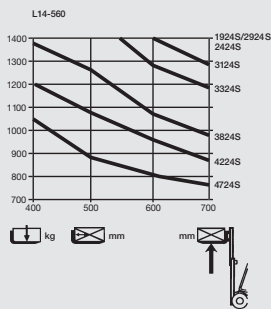
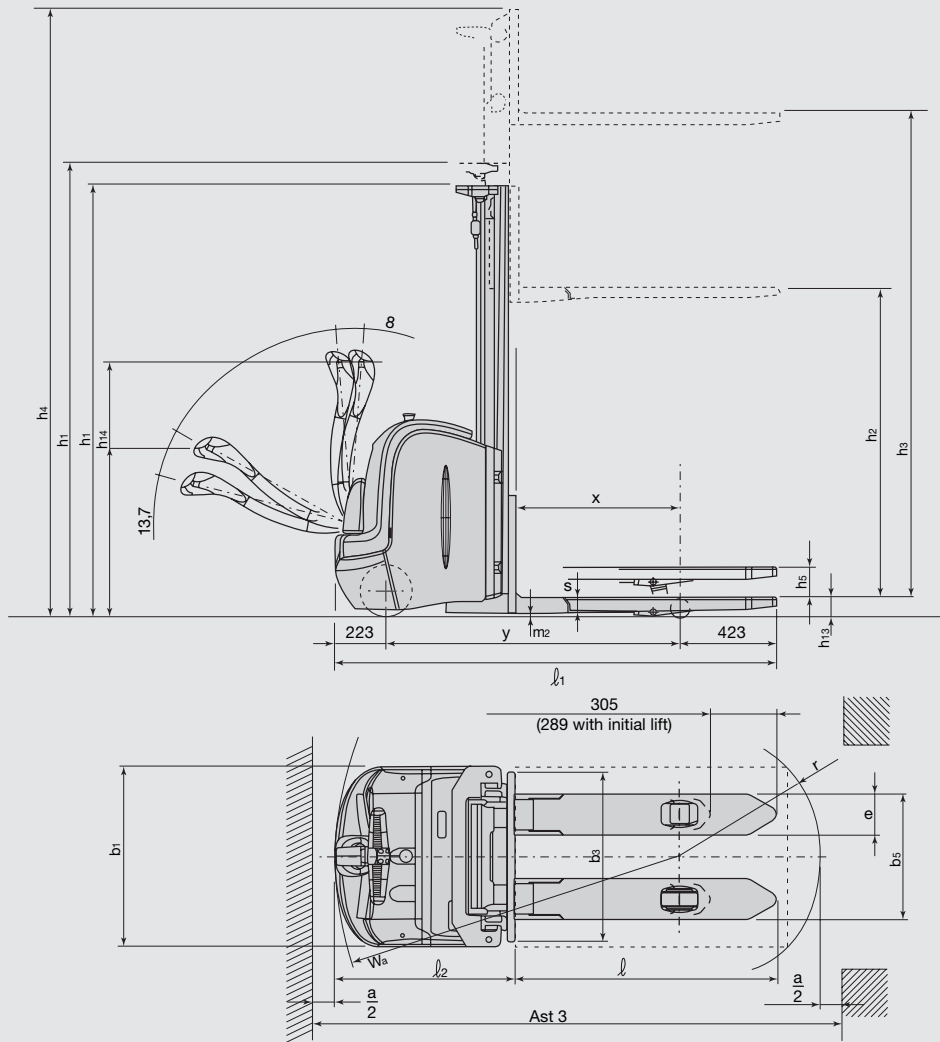

Mast (in mm)	L14	1924S	2424S	2924S	3324S	3824S	4224S	4724S	1924D	2424D	2924D	3324D	3824D	4224D	4266T	4716T
Lift	h3	1924	2424	2924	3324	3824	4224	4724	1924	2424	2924	3324	3824	4224	4266	4716
Lift and fork height	h3+h13	2010	2510	3010	3410	3910	4310	4810	2010	2510	3010	3410	3910	4310	4352	4802
Height lowered	h1	1490	1740	1990	2190	2440	2540	2890	1415	1665	1915	2115	2365	2565	1915	2065
Height extended	h4	2460	2960	3460	3860	4360	4760	5260	2460	2960	3460	3860	4360	4760	4802	5252
Free lift	h2	150	150	150	150	150	150	150	862	1212	1462	1662	1912	2112	1379	1529

Mast (in mm)	L16	1844S	2344S	2844S	3244S	3744S	4144S	4644S	1844D	2344D	2844D	3344D	3744D	4144D	4266T	4716T
Lift	h3	1844	2344	2844	3244	3744	4144	4644	1844	2344	2844	3244	3744	4144	4266	4716
Lift and fork height	h3+h13	1930	2430	2930	3330	3830	4230	4730	1930	2430	2930	3330	3830	4230	4352	4802
Height lowered	h1	1490	1740	1990	2190	2440	2640	2890	1415	1665	1915	2115	2365	2565	1915	2065
Height extended	h4	2380	2880	3380	3780	4280	4680	5180	2380	2880	3380	3780	4280	4680	4760	5252
Free lift	h2	150	150	150	150	150	150	150	879	1129	1379	1579	1829	2029	1379	1529

Other masts on request



# Equipment

## Standard equipment

Linde OptiLift®: fully proportional lifting control on the tiller head  
Initial lift with equalizing linkage (level compensator) on L14i, L16i  
Soft lowering of fork carriage  
Electric power steering  
Linde Digital Control (LDC) with programmable operating parameters  
Automatic speed reduction when cornering

Automatic braking with Linde Brake Control (LBC)  
Polycarbonate/mesh mast protection  
Cushion rubber drive wheel  
Single polyurethane load wheels with string guard  
Polyurethane swiveling castor wheel  
Vertical battery change (2 & 3 PzS)  
Battery charger cable and plug  
Protection to -10°C

## Optional equipment

Drive wheels: polyurethane, wet grip or treaded cushion rubber  
Load wheels: tandem polyurethane, tandem polyurethane greasable  
Twin swiveling castor wheels for heavy duty applications  
Load backrest (h=1000 mm)  
Alternative fork dimensions  
Different mast types and lift heights : standard, duplex, triplex

Ultra fast lifting for loads up to 300 kg  
Side battery change (2 & 3 PzS)  
Battery changing stand or trolley for side battery change  
Built-in charger (vertical battery change, max. 240Ah capacity)  
Cold store version to -35°C  
Other options available on request

# Features

## Chassis & Mast

- Rounded contours, no sharp edges
- Heavy gauge steel chassis results in superior rigidity and durability
- Low chassis skirt for operator safety
- Rigid clearview mast optimizes visibility
- Wide choice of masts



## Initial Lift Versions: L14i, L16i

- Initial lift of load arms increases ground clearance to cope with ramps or dock levellers and bridging plates
- The equalising linkage provides enhanced stability when turning across uneven surfaces
- A 2000 kg load can be lifted using the initial lift function

## Power steering

- Effortless, electric power steering, ensures superior driving comfort
- Precise and easy manoeuvring thanks to the long tiller
- Automatic speed reduction when cornering guarantees stability

## Controls

- OptiLift® fully proportional lift control provides smooth, precise, quiet mast operation
- Control slide mounted centrally on tiller head
- High performance, energy efficient lift unit
- Soft landing of forks protects loads

## Brakes

### Automatic braking

- On releasing the traction butterfly
- By selecting the opposite direction of travel
- By moving tiller to fully up or down position

**Emergency brake:** emergency isolator interrupts all power to the truck and actuates electro-mechanical brake



## Tiller

- The operator's hands are well protected by the sturdy aluminium guard
- Low and central tiller mounting position provides maximum manoeuvrability
- Long tiller ensures operator is well away from the chassis when working
- All traction and lift functions are integrated into the tiller and can be operated with either hand

## Motor

- Powerful, smooth-running 1.2kW DC traction motor
- Adjustable LDC drive controller - all parameters can be customized to suit the application
- No rollback when starting on a gradient
- Max. traction speed of 6 km/h

## Batteries & Chargers

- 24V batteries from 250 Ah (2PzS) to 375 Ah (3PzS)
- Vertical battery change as standard (2 & 3 PzS), side change as option
- Wide range of battery chargers: standard wall-mounted type or high frequency chargers
- Optional built-in charger for batteries with max. 240 Ah capacity

Subject to modification in the interests of engineering progress. Illustrations and technical details non-binding for actual construction. All measurements subject to customary tolerances.

