



Stand-on Double Stacker Capacity 1200 kg L12 LS

SERIES 144

Safety

The operator is always well protected within the chassis contours. A deadman foot switch ensures instant braking response when necessary. The L 12 LS comes rapidly to a smooth stop thanks to an electromagnetic brake which acts proportionally to the load on the forks. Due to its compact chassis, the fork tips are easily visible ensuring safe load handling.

Performance

One of the truck's great strengths is its productivity. Very compact, the L12 LS stand-on double pallet stacker is designed to load/unload and transfer two double-stacked pallets simultaneously with a total weight of 2000 kg. This feature optimises the volume, as well as the speed of loading and unloading lorries. It can also be used as a normal stacker to store and retrieve 1,200 kg loads in narrow aisles and for rapid pallet transfer duties over medium to long distances.

Comfort

Electric power steering with positive feedback makes the truck very easy to control and manoeuvre. A spinner knob on the steering wheel takes the hard work out of tight turns. The 3 position platform height adjustment ensures every operator is able to find the optimum driving position for both comfort and visibility.

Reliability

Rugged construction and the use of tried and tested components and masts make this a truck that can be relied on. The masts are perfectly suited for performing stacking operations in low headroom environments such as lorry trailers. Smooth fork entry into close pallets is assured by the profiled shape of the fork tips and the entry skid. These features guarantee a longer operating life combined with fast, safe and easy load handling.

Service

The Linde stand-on double stacker is designed to deliver high levels of productivity over many years with lower operating costs. A multi-function back-lit instrument display provides the operator with a continuous update of the trucks status. Features such as rapid and easy access to all components and the electronics sealed in aluminium housings protecting them from vibration, dust and moisture all play their part in increasing truck uptime and availability.

Linde Material Handling

Linde

Technical data (according to VDI 2198)

Characteristics	1.1	Manufacturer	LINDE
	1.2	Model designation	L 12 LS
	1.5	Load capacity	Q (kg) 1200/2000
	1.6	Load centre	c (mm) 600
	1.8	Axle centre to fork face	x (mm) 945
	1.9	Wheel base	y (mm) 1856
Weights	2.1	Service weight	kg 1538
	2.2	Axle load with load, drive side/load side	kg 1428/2110
	2.3	Axle load without load, drive side/load side	kg 1066/472
Wheels	3.1	Tyres: Bands, Polyurethane (P), Rubber (R)	R+P/P
	3.2	Tyre size, drive side	mm 250 x 105
	3.3	Tyre size, load side	mm 2 x 85 x 60
	3.4	Auxiliary wheels (dimensions)	mm 2 x 140 x 50
	3.5	Wheels, number drive side / load side (x = driven)	1x + 1/4
	3.6	Track width, drive side	mm 490
	3.7	Track width, load side	mm 380
Dimensions	4.2	Height of mast, lowered	h1 (mm) 1335
	4.3	Free lift	h2 (mm) 150
	4.4	Lift	h3 (mm) 1524
	4.5	Height of mast, extended	h4 (mm) 2175
	4.15	Fork height, lowered	h13 (mm) 86
	4.19	Overall length	l1 (mm) 2236
	4.20	Length to forks face	l2 (mm) 1086
	4.22	Fork dimensions	s/e/l (mm) 55/180/150
	4.24	Width of fork carriage	b3 (mm) 705
	4.25	Fork spread, min/max	b5 (mm) 560
	4.31	Ground clearance, under the mast	m1 (mm) 20
	4.32	Ground clearance, centre of wheelbase	m2 (mm) 22
	4.34	Aisle width with 800 x 1200 pallet lengthwise	Ast (mm) 2700
4.35	Turning radius	Wa (mm) 2030	
Performance	5.1	Travel speed, with/without load	km/h 9.0/10.0
	5.2	Lifting speed, with/without load	cm/s 0.10/0.13
	5.3	Lowering speed, with/without load	cm/s 0.35/0.20
	6.2	Initial lift/Main lift motors, 15% rating	kW 1.0/2.2

Equipment

Standard equipment

Linde OptiLift®: fully proportional control
Electric power steering
Positive steering feedback
Key switch
Linde Digital Control (LDC) with programmable operating parameters
Soft lowering of fork carriage
Automatic braking
Electromagnetic emergency brake acting proportionally to load weight

Multifunction back-lit display: Battery discharge indicator, hour meter, service information and error codes...
Steered wheel position indicator included in display
Ergonomic operator's compartment with 3 position adjustable platform
Operator's backrest: seat type or curved support
Polycarbonate/mesh mast protection
Fork carriage: 560/1150/55mm built out
Cushion rubber drive wheel
Twin Polyurethane castor wheels
Polyurethane tandem load wheels greaseable
Side battery change (4PzS)
Horn
Protection -10°C

Optional equipment

Overhead guard (compulsory if lift height >1,800mm)
Load backrest (h=1000 mm)
Support with A4 clipboard
Multi-purpose mounting bracket (support)
Drive wheels: polyurethane, cushion rubber non-marking or wet grip

Battery roller stands: fixed or on castors
Additional battery housings for spare batteries
Cold store protection to - 35°C

Other options available on request

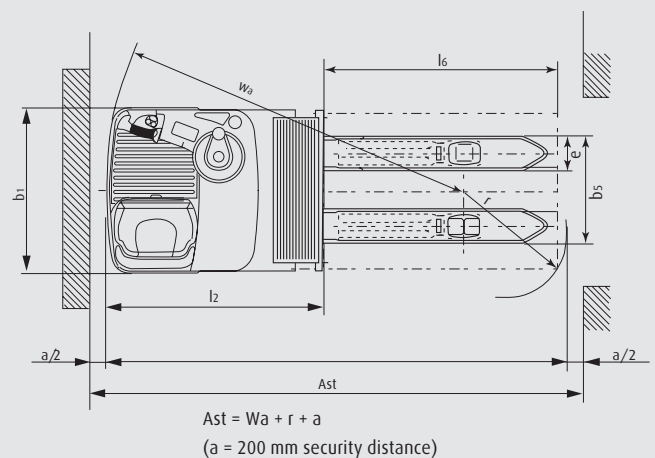
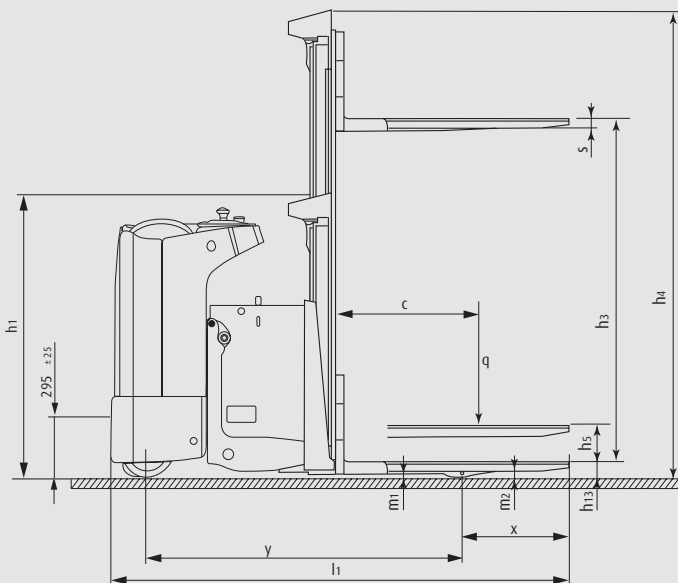

Features

Electric power steering

- Constant and direct relationship between steering wheel position and drive wheel angle
- Electric power steering with positive feedback
- The compact drive unit is mounted off-centre on the right of the truck and can rotate through 180°
- Low steering effort provides easy, precise manoeuvring



Operator's compartment

- Sideways standing position ensures all-round visibility when travelling in either direction
- Choice of operator backrest: seat type or curved support
- All controls are within easy reach
- Ergonomic design suits every operator and makes for easy and safe operation
- 3 platform height adjustments
- Excellent visibility even when handling tall loads

Chassis & Forks

- Rounded contours, no sharp edges
- Sturdy load arms: each fork tip can support a 2,000 kg load without deformation
- The hinged motor cover provides fast, easy access to internal components and servicing points

OptiLift® control

- The proportional OptiLift® control brings quiet smoothness and precision
- Controls are close to the handle for easy intuitive use
- High performance, energy efficient lift unit
- Soft lowering of forks protects loads

Workstation

- Linde multi-function instrument display provides a continuous update of the trucks status
- Steered wheel position indicator included in display
- Storage compartment under seat type backrest



Motor

- Self-ventilating 2.0 kW DC drive motor designed for maximum performance in intensive applications
- Adjustable digital controller: all operating parameters can be customized to suit the application
- Hill start without rollback
- Booster effect for fast acceleration
- Maximum travel speed of 10 km/h

Braking

- Electromagnetic braking on release of dead man pedal with hydraulic braking assistance proportional to the load on the forks
- Emergency circuit isolator: interrupts power to the truck and initiates electromagnetic braking
- Automatic electric braking on release of the traction control

Batteries & chargers

- 24V batteries: capacities 500 Ah (4Pz5)
- Standard side batter change with battery on rollers
- Wide range of battery chargers

