



Electric Pallet Stackers Capacity 1000 - 1200 kg L10B, L10, L12, L12i

SERIES 1172

Safety

Sinergo® interface is implemented on Linde pedestrian pallet stackers. The hand guards of the off-centred tiller head effectively shield hands and keep the operator safely within the truck's contours with excellent visibility through the mast. The long tiller mounted low down on the chassis ensures ample safety clearance between operator and truck.

Performance

The combination of a new AC motor and Linde LAC digital control makes these pallet stackers highly efficient. Operating parameters can be adjusted to match any application. The OptiLift® mast control provides accurate, fully proportional lifting and assures quiet smooth operation.

Comfort

Through Sinergo®, all controls on the ergonomic tiller can be easily operated by either hand. A Creep speed button offers utmost manoeuvrability in confined areas. Proportional speed automatically alters traction speed in relation to the truck/operator distance. Finished in tactile materials, these trucks deliver accurate load handling for better productivity.

Reliability

Despite their visual appeal, these pallet stackers are rugged and durable. The mast channels are made from high grade rolled steel sections for strength and durability. Strong, long-lasting, with memory effect, Exxtral® motor and battery cover protect the technical compartment from outside shocks. In addition, a built-out fork carriage with thinner forks is available to protect the mast when handling gitterboxes.

Service

It is not just about the truck in operation: a maintenance-free AC motor maximises uptime reducing operating costs. All truck data is immediately and easily accessible to the service engineer via the CAN-bus architecture. Fast, easy access to all internal components ensures service tasks are completed with a minimum of delay.

Linde Material Handling

Linde

Technical Data (According to VDI 2198)

Characteristics	1.1	Manufacturer		LINDE	LINDE	LINDE
	1.2	Model designation		L10B*	L10	L12
	1.3	Power unit		Battery	Battery	Battery
	1.4	Operation		Pedestrian	Pedestrian	Pedestrian
	1.5	Load capacity	Q (t)	1	1	1.2
	1.6	Load centre	c (mm)	600	600	600
	1.8	Axle centre to fork face	x (mm)	711 ¹	695 ¹	695 ¹
	1.9	Wheelbase	y (mm)	1157 ¹	1157 ¹	1157 ¹
Weights	2.1	Service weight	(kg)	708 ²	788 ²	788 ²
	2.2	Axle load with load, front/rear	(kg)	670/1038	695/1093	720/1266
	2.3	Axle load without load, front/rear	(kg)	518/190 ²	572/216 ²	572/216 ²
Wheels / Tyres	3.1	Tyres		Rubber ⁴	Rubber ⁴	Rubber ⁴
	3.2	Tyre size, front		230 x 75	230 x 75	230 x 75
	3.3	Tyre size, rear		2x 85 x 100	2x 85 x 100	2x 85 x 100
	3.4	Auxiliary wheels (dimensions)		140 x 54	140 x 54	140 x 54
	3.5	Wheels, number front/rear (x = driven)		1x+1/2	1x+1/2	1x+1/2
	3.6	Track width, front	b10 (mm)	518 ³	518 ³	518 ³
	3.7	Track width, rear	b11 (mm)	380 ³	380 ³	380 ³
Dimensions	4.2	Height of mast, lowered	h1 (mm)	2390 ⁵	1940 ⁵	1940 ⁵
	4.3	Free lift	h2 (mm)	150 ⁵	1462 ⁵	1462 ⁵
	4.4	Lift	h3 (mm)	1912 ^{5*}	2924 ^{5*}	2924 ^{5*}
	4.5	Height of mast, extended	h4 (mm)	2393 ⁵	3402 ⁵	3402 ⁵
	4.6	Initial lift	h5 (mm)	-	-	-
	4.9	Height of tiller arm in operating position, min/max	h14 (mm)	650 / 1190	650 / 1190	650 / 1190
	4.15	fork height, lowered	h13 (mm)	85	85	85
	4.19	Overall length	l1 (mm)	1772 ⁷	1788 ⁷	1788 ⁷
	4.20	Length to fork face	l2 (mm)	622 ⁷	638 ⁷	638 ⁷
	4.21	Overall width	b1/b2 (mm)	800 ⁷	800 ⁷	800 ⁷
	4.22	Fork dimensions	s/e/l (mm)	65x180x1150	65x180x1150	65x180x1150
	4.24	Width of fork carriage	b3 (mm)	534	534	534
	4.25	Fork spread, min/max	b5 (mm)	560	560	560
	4.32	Ground clearance, centre of wheelbase	m2 (mm)	30	30	30
	4.33	Aisle width with pallet 1000 x 1200 across forks	Ast (mm)	-	-	-
4.34	Aisle width with pallet 800 x 1200 along forks	Ast (mm)	2292/2149 ²	2276 ² /2137 ^{2M}	2276 ² /2137 ^{2M}	
4.35	Turning radius	Wa (mm)	1460	1432 ²	1432 ²	
Performance	5.1	Travel speed, with/without load	(km/h)	6 / 6 ¹	6 / 6 ¹	6 / 6 ¹
	5.2	Lifting speed, with/without load	(m/s)	0.09/0.2	0.1/0.2	0.08/0.225
	5.3	Lowering speed, with/without load	(m/s)	0.23 / 0.23 ²	0.35 / 0.35 ²	0.4 / 0.3 ²
	5.8	Maximum climbing ability, with/without load	(%)	5 / 10	5 / 10	5 / 10
	5.9	Acceleration time, with/without load	(s)	8 / 7	8 / 7	8.3 / 7
	5.10	Service brake		Electro-magnetic	Electro-magnetic	Electro-magnetic
Drive	6.1	Drive motor, 60 minute rating	(kW)	1.2	1.2	1.2
	6.2	Lift motor rating at 15%	(kW)	0.9	1	2.45
	6.3	Battery according to DIN 43531 /35/36 A,8,C,no		no	no	no
	6.4	Battery voltage/rated capacity (5h)	(V/Ah)	24/180	24/180	24/180
	6.5	Battery weight (± 5%)	(kg)	195	195	195
	6.6	Power consumption according to VDI cycle	(kWh/h)	0.72	0.75	1
Others	8.1	Type of drive control		LAC	LAC	LAC
	8.4	Noise level at operator's ear	(dB(A))	65	65	65

1) (± 5 mm)

2) with/without initial lift

3) (± 10%)

4) Solid rubber + polyurethane / polyurethane

5) Calculated with the VDI guidelines 3579)

6) With creep speed = tiller in vertical position

7) (± 5%)

8) L10 B only with mast 1462E, 1912E and 2424S, see c

LINOE
L12i
Battery
Pedestrian
1.2
600
780/667 ^{1/2}
1362/1249 ^{1/2}
909°
759/1350
643/266°
Rubber ^f
230 x 75
2x 85 x 100
140 x 54
1x+1/2
518°
380°
1940°
1462°
4386°
4868°
130
650 / 1190
91
1908°
758°
800°
65x180x1150
534
560
30
-
2421 ^f /2261 ^a
1641/1528 ^a
6 / 6 ^f
0.08/0.225
0.4 / 0.3 ^f
10 / 15
8.3 / 7
Electro-magnetic
1.2
2.45
no
24/225
200
1
LAC
65

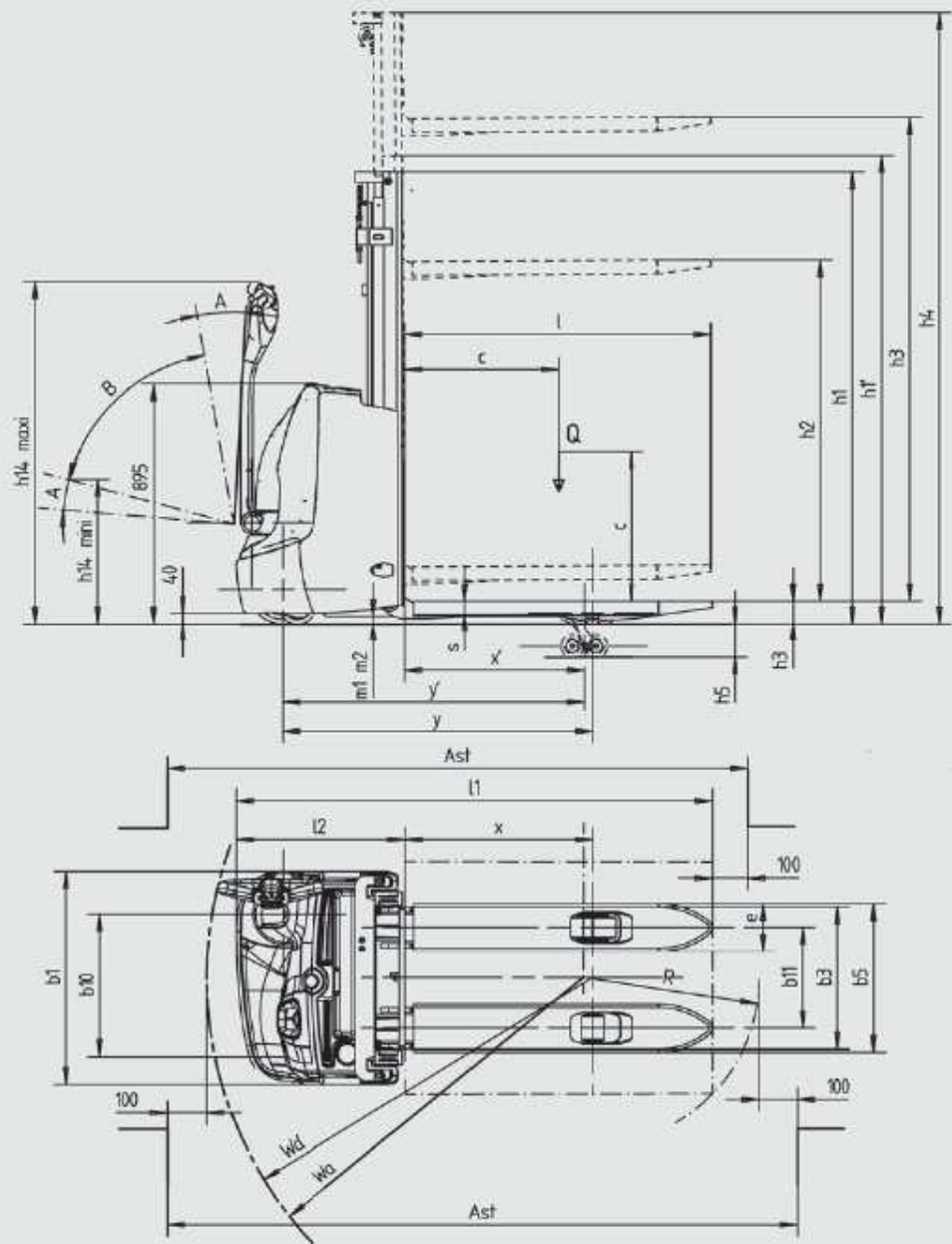

$$Ast = Wa + \sqrt{(l_6 - x)^2 + \left(\frac{b_{12}}{2}\right)^2} + a$$

Ast = Wa + R + a
 Safety clearance a = 200 mm



Masts (L10/L12) (n mm)		1462 E	1912 E	2024 S	2424 S	2924 S	3324 S	3824 S	4224 S
Lift	h3	1462	1912	2024	2424	2924	3324	3824	4224
Lift + fork height	h3+h13*	1547	1997	2109	2509	3009	4309	3909	4309
Height lowered	h1*	1940	2390	1490	1690	1940	2140	2390	2590
Height raised	h4	1943	2393	2502	2902	3402	3802	4302	4702
Free lift	h2	1462	1912	150	150	150	150	150	150

Masts (L10/L12) (n mm)		2024 D	2424 D	2924 D	3324 D	3824 D	4224 D	3636 T	4386 T
Lift	h3	2024	2424	2924	3324	3824	4224	3636	4386
Lift + fork height	h3+h13*	2109	2509	3009	3409	3909	3409	3721	4471
Height lowered	h1*	1490	1690	1940	2140	2390	2590	1690	1940
Height raised	h4	2502	2902	3402	3802	4302	4702	4118	4868
Free lift	h2	1012	1212	1462	1662	1912	2112	1212	1462

* Initial Lift h5 = 130mm

Standard Equipment/Optional equipment

Standard Equipment

- Sinergo®, the operator / truck interface
- Long tiller with low mounting point and off-set head made out of Grivory®
- Exxtral® motor and battery cover
- Creep speed control (L12, L12i)
- Proportional speed control (L12, L12i)
- End-of-stroke resistance
- Storage compartments
- OptiLift® proportional lift system (L10, L12, L12i)
- Hand protection at rear of mast (polycarbonate or steel mesh)

Multifunction display with hourmeter, maintenance indication, battery discharge indicator and internal fault code indication
Key switch or LFMgo (PIN-code access)

- AC motor
- Linde LAC controller
- CAN-bus architecture
- Electromagnetic brake
- Automatic parking brake
- Cushion rubber drive wheel
- Single polyurethane load wheels
- Fork length: 1150 mm
- Width over forks: 560 mm
- Initial lift (L12i)
- Built-in or built-out carriage
- Protection to -10°C
- Vertical 2PzS BS battery change (L10B, L10, L12)
- Vertical 3PzS BS battery change (L12i)
- Horn
- Clipboard

Optional equipment

- Drive wheels: polyurethane, wet grip, non marking cushion, treaded cushion
- Load wheels: Tandem polyurethane, tandem polyurethane greaseable
- Alternative fork lengths and widths
- Load backrest
- Fleet management LFMaccess and LFMbasic

- Creep speed control (L10)
- Proportional speed control (L10)
- Cold store protection to -35°C
- Automatic battery watering system
- Built-in charger
- High frequency charger

Other options available on request

Features

Steering system

- Proportional speed control varies truck speed automatically in relation to the tiller angle for safe, comfortable and productive operation
- A Creep speed button ensures high manoeuvrability in confined areas when operating at low speeds with the tiller in the upright position
- End-of-stroke resistance on the tiller avoids accidental, abrupt braking
- Soft tiller fold-back slows down the tiller when returning into upright position, avoiding the tiller snapping on the motor cover

Working station & Display

- Wide, deep storage compartment for shrink wrap, pens, markers etc.
- Strong Extrak[®] motor and battery cover last the lifetime of the truck
- Multifunctional display as standard with hourmeter, maintenance indication, battery discharge indicator, fault code indication



AC motor & Booster effect

- Powerful, smooth-running AC motor, 1.2kw (at 100% output)
- Traction speed adjustable up to 6km/h, laden or unladen
- Booster effect provides higher torque when additional power is needed
- No roll-back on hill starts



Lifting system

- OptiLift[®] mast control provides accurate, fully proportional lifting as well as smooth, quiet operation
- Soft landing of the forks protects load when lowering
- Wide range of mast options available
- Choice of standard or built-out carriage depending on application
- Initial lift on L12i ensures ramps and dock levellers are easily negotiated

Tiller & Tiller head

- Off-set, ergonomic Grivory tiller head ensures safety and visibility
- Long tiller with low mounting point provides safety clearance between operator and chassis
- Wrap-around hand protection
- Comfortable controls, operable with either hand and gloves



Braking system

- Highly efficient electromagnetic brake applied by moving tiller to fully up or down position
- Automatic braking on releasing traction butterfly or by reversing direction
- Truck slows before coming to a stop, remaining under total control at all times

Chassis

- Compact, rounded shape avoids snagging
- Highly resistant, robust steel construction
- Low chassis skirt protects operator's feet
- Mast bolted to chassis for maximum rigidity

Maintenance and

CAN-bus architecture

- Zero maintenance, moisture and dust-proof AC motor
- CAN-bus architecture enables fast, easy access to all truck data
- Individually adjustable parameters via diagnostic plug
- Rapid and convenient access to main components via front service panel

Subject to modification in the interests of progress. Illustrations and technical details not binding for actual constructions. All dimensions subject to usual tolerances.

