



Diesel and LPG Forklift Trucks Capacity 4000 – 5000 kg H 40, H 45, H 50

SERIES 394

Safety

Linde ProtectorFrame: Overhead guard and frame form a structural unit, resulting in maximum stability and safety. Top-mounted tilt jacks allow use of slim mast upright sections for optimum visibility.

Performance

Advanced engine and drive technology combined with the original Linde Load Control system enables the operator to use the truck's vast potential to maximise productivity. Comfortable and precise fingertip control of all mast functions.

Comfort

Linde brings to this forklift a generously sized automobile-class workspace. Designed to the most advanced ergonomic standards. Spacious cab interior, adjustable armrest, suspension seat and functional positioning of easy-actuation controls: basic to fast, stress-free working.

Reliability

Proven in tough sustained operation. Isolation of the cab from the mast, drive axle and chassis results in reduced shock and vibration. Maintenance-free mounting of axles and tilt jacks cuts downtime and operating costs.

Productivity

Effective and cost-efficient at work: The original Linde hydrostatic drive cost does away with gearshift, clutch, differential and drum brakes. As a result, servicing costs are low, truck uptime is high and productivity is enhanced.

Linde Material Handling

Linde

Technical data

Characteristics	1.1	Manufacturer		LINDE	LINDE
	1.2	Model designation		H 40 D	H 40 T
	1.3	Power unit: battery, diesel, petrol, LP gas, mains power		Diesel	LPG
	1.4	Operation: manual, stand-on, seated		Seated	Seated
	1.5	Load capacity	Q (kg)	4000	4000
	1.6	Load centre	c (mm)	500	500
	1.8	Axle centre to fork face	x (mm)	483	483
	1.9	Wheelbase	y (mm)	1998	1998
	Weight	2.1	Service weight	kg	5785
2.2		Axle load with load, front/rear	kg	8610/1180	8665/1305
2.3		Axle load without load, front/rear	kg	2640/3145	2695/3270
Wheels and tyres	3.1	Tyres: solid rubber, superelastic, pneumatic (P)		SE (P)	SE (P)
	3.2	Tyre size, front		250-15	250-15
	3.3	Tyre size, rear		250-15	250-15
	3.5	Wheels, number front / rear (x = driven)		2 x (4x)/2 ²⁾	2 x (4x)/2 ²⁾
	3.6	Track width, front	b10 (mm)	1221 (1499) ¹⁾	1221 (1499) ¹⁾
	3.7	Track width, rear	b11 (mm)	1122	1122
	Dimensions	4.1	Mast lift, forward/backward	α/β (°)	5.0/9.0
4.2		Height of mast, lowered	h1 (mm)	2420 (2375/2375) ²⁾³⁾	2420 (2375/2375) ²⁾³⁾
4.3		Free lift	h2 (mm)	150 (1611/1614) ³⁾	150 (1611/1614) ³⁾
4.4		Lift	h3 (mm)	3100 (3130/4675) ²⁾³⁾	3100 (3130/4675) ²⁾³⁾
4.5		Height of mast, extended	h4 (mm)	3895 (3895/5436) ²⁾³⁾	3895 (3895/5436) ²⁾³⁾
4.7		Height of overhead guard	h6 (mm)	2383	2383
4.8		Height of seat	h7 (mm)	1226	1226
4.12		Towing coupling height	h10 (mm)	703	703
4.19		Overall length	l1 (mm)	3984	3984
4.20		Length to fork face	l2 (mm)	2984	2984
4.21		Overall width	b1/b2 (mm)	1446/1423 (2003/1423) ¹⁾	1446/1423 (2003/1423) ¹⁾
4.22		Fork dimensions	s/e/l (mm)	50 x 120 x 1000	50 x 120 x 1000
4.23		Fork carriage to DIN 15 173, class / form A, B		3A	3A
4.24		Width of fork carriage	b3 (mm)	1350 (1750) ⁴⁾	1350 (1750) ⁴⁾
4.31		Ground clearance, mast	m1 (mm)	158	158
4.32		Ground clearance, centre of wheelbase	m2 (mm)	201	201
4.33		Aisle width pallet 1000 x 1200 across forks	Ast (mm)	4355	4355
4.34		Aisle width pallet 800 x 1200 along forks	Ast (mm)	4555	4555
4.35		Turning radius	Wa (mm)	2672	2672
4.36		Minimum pivoting point distance	b13 (mm)	700	700
Performance	5.1	Travel speed, with /without load	km/h	21/21	21/21
	5.2	Lifting speed, with /without load	m/s	0.53/0.56	0.53/0.56
	5.3	Lowering speed, with /without load	m/s	0.52/0.57	0.52/0.57
	5.5	Tractive force, with /without load	N	28541/20570	28540/21160
	5.7	Climbing ability with /without load	%	29.0/34.0	28.0/33.0
	5.9	Acceleration time, with /without load	s	5.7/4.8	5.6/4.8
	5.10	Service brake		hydrostatic	hydrostatic
Drive	7.1	Engine manufacturer /type		VW CBJB	VW/BMF
	7.2	Engine performance according to ISO 1585	kW	55	55
	7.3	Rate speed	min ⁻¹	2800	2800
	7.4	Number of cylinders	cm ³	4/1968	6/3189
	7.5	Fuel consumption according to VDI cycle	l/h; kg/h	4.6 ⁵⁾	4.6
Others	8.1	Type of drive control		hydrost. infinitely variable	hydrost. infinitely variable
	8.2	Working pressure for attachments	bar	170	170
	8.3	Oil flow for attachments	l/min	48	48
	8.4	Noise level, at operator's ear to EN 12053	dB(A)	79 (75) ⁶⁾	77 (73) ⁶⁾
	8.5	Towing coupling, design / type		DIN 15 170-H	DIN 15 170-H

1) Figures in parentheses for SE twin tyres: H 40, 250-15, H 45/H 50, 8.25-15

2) With 150 mm free lift on standard mast

3) Figures in parentheses for duplex/triplex mast

4) Option: Figure in parentheses for twin tyres

5) Figure higher than previous due to amended measuring method in VDI Code 2198

6) Figures in parentheses for overhead guard 6 (cabin)

LINDE	LINDE	LINDE	LINDE
H45D	H45T	H50D	H50T
Diesel	LPG	Diesel	LPG
Seated	Seated	Seated	Seated
4500	4500	5000	5000
500	500	500	500
525	525	535	535
2038	2038	2078	2078
6295	6480	6580	6763
9555/1240	9613/1367	10371/1209	10425/1335
2790/3505	2850/3630	2880/3700	2935/3830
SE (P)	SE (P)	SE (P)	SE (P)
300-15	300-15	300-15	300-15
250-15	250-15	250-15	250-15
2x (4x)/2 ²⁾	2x (4x)/2 ²⁾	2x (4x)/2 ²⁾	2x (4x)/2 ²⁾
1190 (1499) ¹⁾	1190 (1499) ¹⁾	1190 (1499) ¹⁾	1190 (1499) ¹⁾
1122	1122	1122	1122
5.0/9.0	5.0/9.0	5.0/9.0	5.0/9.0
2421(2376/2376) ^{2) 3)}	2421(2376/2376) ^{2) 3)}	2421(2376/2376) ^{2) 3)}	2421(2376/2376) ^{2) 3)}
150 (1460/1460) ³⁾	150 (1460/1460) ³⁾	150 (1460/1460) ³⁾	150 (1460/1460) ³⁾
3000 (3030/4525) ^{2) 3)}	3000 (3030/4525) ^{2) 3)}	3000 (3030/4525) ^{2) 3)}	3000 (3030/4525) ^{2) 3)}
3916 (3946/5441) ^{2) 3)}	3916 (3946/5441) ^{2) 3)}	3916 (3946/5441) ^{2) 3)}	3916 (3946/5441) ^{2) 3)}
2416	2416	2416	2416
1264	1264	1264	1264
726	726	719	719
4066	4066	4116	4116
3066	3066	3116	3116
1448/1423 (1988/1423) ¹⁾	1448/1423 (1988/1423) ¹⁾	1448/1423 (1988/1423) ¹⁾	1448/1423 (1988/1423) ¹⁾
50 x 120 x 1000	50 x 120 x 1000	60 x 130 x 1000	60 x 130 x 1000
3A	3A	3A	3A
1350 (1750) ⁴⁾	1350 (1750) ⁴⁾	1350 (1750) ⁴⁾	1350 (1750) ⁴⁾
205	205	203	203
236	236	235	235
4433	4433	4480	4480
4633	4633	4680	4680
2708	2708	2745	2745
700	700	700	700
24/24	24/24	24/24	24/24
0.53/0.56	0.53/0.56	0.48/0.50	0.48/0.50
0.52/0.57	0.52/0.57	0.50/0.56	0.50/0.56
25285/21841	25285/22350	25285/22375	25285/23040
22.0/32.0	22.0/32.0	21.0/32.0	20.0/32.0
6.0/5.2	5.9/5.2	6.2/5.5	6.1/5.5
hydrostatic	hydrostatic	hydrostatic	hydrostatic
VW CBJB	VW/BMF	VW CBJB	VW/BMF
55	55	55	55
2800	2800	2800	2800
4/1968	6/3189	4/1968	6/3189
4.8 ⁵⁾	4.8	5 ⁵⁾	5.0
hydrost. infinitely variable	hydrost. infinitely variable	hydrost. infinitely variable	hydrost. infinitely variable
170	170	170	170
48	48	48	48
79 (75) ⁶⁾	77 (73) ⁶⁾	79 (75) ⁶⁾	77 (73) ⁶⁾
DIN 15 170-H	DIN 15 170-H	DIN 15 170-H	DIN 15 170-H

Lifting capacity diagrams

H40

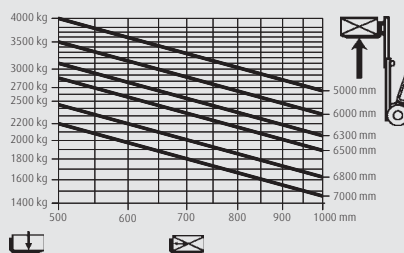

H45

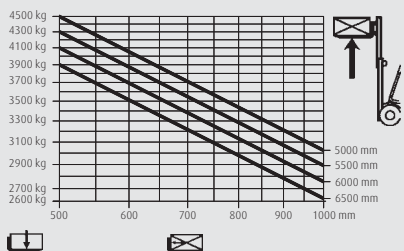

H50

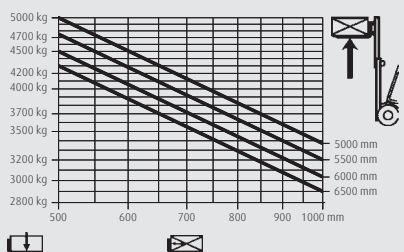

For Standard and Duplexmasts with standard equipment

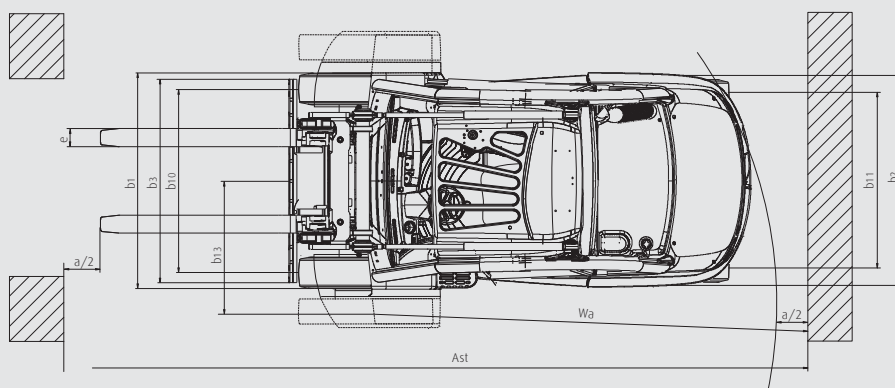
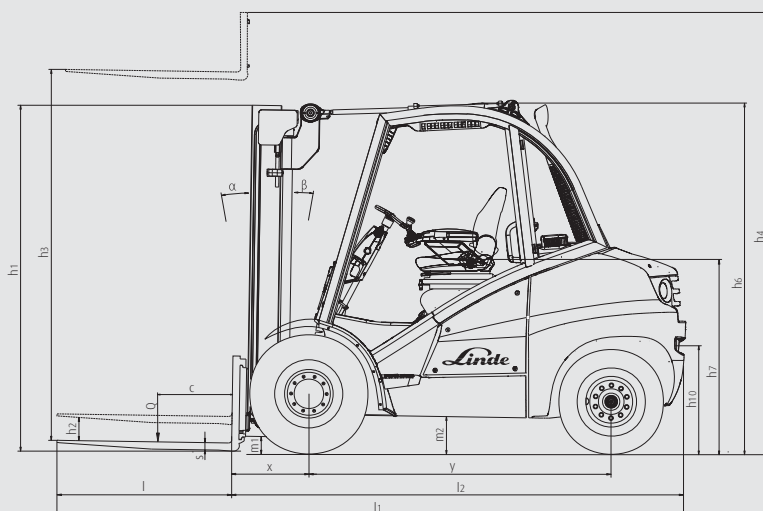

Overall height and lift heights, Standard (in mm)

Lift	h3	H 40 - 50	3000	3100	3200	3700	4100	4400	5000	5400
Height of Mast, lowered	h1	H 40	-	2420	2470	2720	2920	3070	3370	5570
		H 45/50	2421	2471	2521	2771	2971	3121	3421	3621
Height of Mast, extended	h4	H 40	-	3895	3995	4495	4895	5195	5795	6195
		H 45/50	3916	4016	4116	4616	5016	5316	5916	6316
Free lift	h2	H 40 - 50	150	150	150	150	150	150	150	150

Overall height and lift heights, Duplex (in mm)

Lift	h3	H 40 - 50	3030	3130	3730	4130	-	-	-	-
Height of Mast, lowered	h1	H 40	-	2375	2675	2875	-	-	-	-
		H 45/50	2376	2426	2726	2926	-	-	-	-
Height of Mast, extended	h4	H 40	-	3894	4494	4894	-	-	-	-
		H 45/50	3946	4046	4646	5046	-	-	-	-
Free lift	h2	H 40	-	1611	1911	2111	-	-	-	-
		H 45/50	1460	1510	1810	2010	-	-	-	-

Overall height and lift heights, Triplex (in mm)

Lift	h3	H 40 - 50	4525	4675	5365	5865	6315	-	-	-
Height of Mast, lowered	h1	H 40	-	2375	2625	2825	2975	-	-	-
		H 45/50	2376	2426	2676	2876	3026	-	-	-
Height of Mast, extended	h4	H 40	-	5436	6426	6626	7076	-	-	-
		H 45/50	5441	5591	6281	6781	7231	-	-	-
Free lift	h2	H 40	-	1614	1864	2064	2214	-	-	-
		H 45/50	1460	1510	1760	1960	2110	-	-	-

Alternative lift heights available on request.

Standard and optional equipment

Standard equipment

Truck

Linde twin drive pedals to control forward/reverse travel and braking

Linde Load Control integrated in armrest

Hydraulic-suspension comfort-class seat with extensive range of adjustment

Adjustable-angle steering wheel

Low-effort, responsive and virtually play-free hydrostatic steering with on-demand power assist

High safety and stability ensured by Linde ProtectorFrame

Air intake filter with integral cyclone separator

High-performance hydraulic filter concept, preserves maximum oil purity and extends life of all hydraulic components

Anti-glare display including fuel gauge, clock, hour meter and servicing information

Control lights on display for engine oil pressure, engine overheating, parking brake, audible warning signal for engine and hydraulic oil temperature, blocked intake filter and low fuel level

Plenty of storage space for writing utensils, beverage cans, etc.

Superelastic tyres

LPG truck fitted with two-way catalytic converter and the gas cylinder mount is ergonomically designed for easy changing

LPG truck is fitted with accurate ultrasonic fuel level indicator for exchange cylinders

LPG volumetric fuel tank version has a fuel level indicator in the display consol

Mast

Standard mast lift height h3 = 3,100/3,000 mm (H 40, H 45/H 50)

Standard, duplex and triplex masts

Top-mounted tilt jacks

Zero-maintenance mast and tilt jack cylinder mounting

Rubber-mounted joints to cushion shock and vibration

Electronic tilt angle limiting

Fork length l = 1,000 mm

Fork carriage width b3 = 1,350 mm

Options

Single drive pedal with direction selector positioned on armrest

Standard masts from 3,000 mm to 5,400 mm lift

Duplex masts (full free lift) from 3,030 mm to 4,130 mm lift

Triplex masts (full free lift) from 4,525 mm to 6,315 mm lift

Integral sideshift

Load backrest

One or two auxiliary hydraulic circuits for all mast types

Alternative fork lengths

Overhead guard can be upgraded to full cabine with roof, front and rear screens and doors (also available with tinted glass)

Wiper-washers for front, rear and roof screens

Seats providing additional comfort (lumbar support, seat heater) and adjustments

Cab heater with integral pollen filter

Radio with cassette player and speakers

Roof blind, clipboard, interior lighting, height-adjusting steering column

Truck lighting, work lamps

Mirrors

Highway specifications

Integral diesel particulate filter with charge status indicator on the display consol

Air precleaner

Audible reversing alarm, flasher and strobe beacons

LPG truck fitted with accurate ultrasonic fuel level indicator for swap cylinders

Biodiesel (RME) fuel version

Custom paintwork

Other options available on request

Features

Original Linde hydrostatic drive

- Responsive, smooth and precise driving
- No clutch, differential or drum brakes; hydrostatic drive assumes function of service brake
- Robust drive system, well proven in severest duty
- Low maintenance costs and long life



Linde ProtectorFrame

- Safe and robust chassis, enclosed on all sides
- Engine hood and servicing doors open wide for convenient access to all components

Linde twin drive pedals

- Quick change of forward/reverse direction without changing feet on pedals
- Short pedal stroke
- No leg fatigue
- Increased productivity

Linde Load Control

- Accurate, safe load handling
- Effortless fingertip control of all mast functions
- Traction and lift functions completely separate

High-economy engine technology

- Diesel and LPG engines incorporating most advanced technology
- High torque
- Low fuel consumption
- Low exhaust gas and soot emission levels



Linde operator compartment

- Designed to advanced ergonomic standards
- Spacious cab with automobile-equivalent legroom
- Excellent visibility of load and surroundings due to slim-line mast sections
- Cushioned drive axle reduces road shock
- Minimum driving noise

Linde Truck Control

- Reliable electronic controller
- High dependability resulting from redundant monitoring systems
- Automatic control of engine speed as function of load
- Casing totally enclosed for protection from dust and dirt

Linde clear-view mast

- Superb visibility through slim-profile sections of mast
- Full load capacity up to maximum lift height
- Exceptional residual capacity
- Zero-maintenance rubber mounting of mast and tilt jacks
- Electronic limiting of tilt angle

Subject to modification in the interests of engineering progress. Illustrations and technical details non-binding for actual construction. All measurements subject to customary tolerances.